

# Tappets

Applies to  
Big Twin and XL

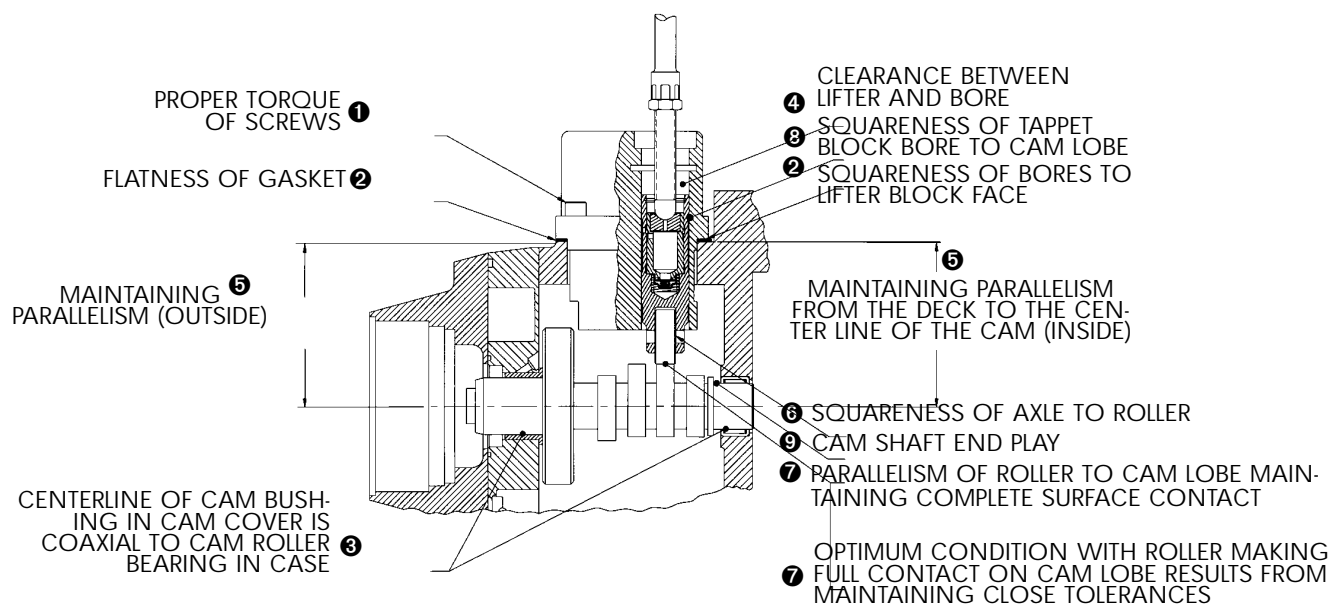

## Congratulations

You and your Harley® have just taken the first steps towards owning the finest precision designed and engineered valve train components known to the Harley-Davidson® market. JIMS® tappets, tappet blocks and cam covers surpass the stock requirements and demands of the present and future Harley-Davidson® motorcycle.

To achieve the best life possible from this tappet (or any other valve train part) you must be aware of some very important issues.

1. Clean! Clean! Clean! You must use the best possible oil and oil filter available for your Harley-Davidson®. Use only motorcycle or air cooled type engine oil. No Substitutes!
2. If these tappets are being installed in a motor that has had motor problems, or was rebuilt, wash out oil tank, oil feed lines and motor.
3. If these tappets are replacing a previous tappet and cam problem, please make sure you know what caused the problem in the first place.
4. The first area of concern is that the tappet roller must seat flat on cam. JIMS® tappets are square from the tappet body to the axle bore within .0002". If the roller is not seated flat on the cam, it will fail within a short period of time.
5. Second concern: The same holds true for the tappet blocks. JIMS® tappet blocks are machined to hold the bores perpendicular to the mounting flange within  $\pm .0002$  of an inch.
6. The next important concern is alignment of the cam itself. First, the cam will be, or should be, parallel from the two bearing journals to the lobes within  $\pm .0002$ , (this is just the cam). With the cam installed in the motor this can be a lot different. For this reason, JIMS® has a precision machined cam cover to hold your cam to within .0002" of cam centerline.

As you can see from some of the examples there are a lot of possible reasons for your valve train to have a shortened life. For this reason JIMS® is continuously helping you achieve the longest possible life for your valve train.

### WARRANTY

All JIMS® parts are guaranteed to the original purchaser to be free of manufacturing defects in materials and workmanship for a period of six (6) months from the date of purchase. Merchandise that fails to conform to these conditions will be repaired or replaced at JIMS® option if the parts are returned to us by the dealer (purchaser) within the six (6) month warranty period or within ten (10) days thereafter.

In the event warranty service is required, the original purchaser must call or write JIMS® immediately with the problem. Some problems can be rectified by a telephone call and need no further course of action. A part suspected of being defective must not be replaced by a dealer without prior authorization from JIMS®. If it is deemed necessary for JIMS® to make an evaluation to determine whether the part is defective, it must be packaged properly to prevent further damage and be returned prepaid to JIMS® with a copy of the original invoice of purchase and a detailed letter outlining the nature of the problem, how the part was used and the circumstances at the time of failure. If after an evaluation has been made by JIMS® and the part was found to be defective, repair, replacement or credit will be granted.

### ADDITIONAL WARRANTY PROVISIONS

- 1.) JIMS® shall have no obligation in the event a JIMS® part is modified by any other person or organization.
- 2.) JIMS® shall have no obligation if a JIMS® part becomes defective in whole or in part as a result of improper installation, improper maintenance, improper use, abnormal operation, or any other misuse or mistreatment of the part.
- 3.) JIMS® shall not be liable for any consequential or incidental damages resulting from the failure of a JIMS® part, the breach of any warranties, the failure to deliver, delay in delivery, delivery in nonconforming condition, or for any other breach of contract or duty between JIMS® and a customer.
- 4.) JIMS® parts are designed exclusively for use in Harley-Davidson® Motorcycles. JIMS® shall have no warranty or liability obligation if a JIMS® part is used in any other application.

**"From the Track... To the Street!"**

555 Dawson Drive, Camarillo, CA 93012 • Phone 805-482-6913 • Fax 805-482-7422



# Instruction Sheet For #2459, 2460 & 2461



## Power Glide™ Tappet

**Big Twin - Use on 1953-84  
Pan and Shovel Models**

Install tappets per H.D.® Service Manual

Use with JIMS® pushrods No.2404 for panhead or JIMS®2369 for shovel heads or H.D.® style pushrods #17904-66, or equivalent.

1. These tappets will work best in Jims® Tappet Blocks #1095 (supersedes #18602/3-80A), with a running clearance of .0007-.0012.

2. Jims® Power Glide™ Tappet can also be run in H.D.® blocks, at a running clearance of .0007-.0012.
3. Install lifters in tappet blocks with oil hole on tappet facing each other in the blocks.
4. Jims® Power Glide™ Tappets are assembled with a small amount of oil to ease in the adjustment. This way you will not have to bleed down the tappet at the time of final adjustment.
5. With the Power Glide™ Tappet installed, start with the front tappet at the lowest point on the cam, extend the pushrod to zero lash (no up and down play, this is not moving the hydraulic unit from snap ring down).
6. Extend the pushrod adjuster 15 wrench flats if your pushrods have 24 threads per inch (H.D. pushrods® have 32 threads per inch), 17 wrench flats if pushrods have 28 threads per inch, 18 wrench flats if pushrods have 32 threads per inch, 24 wrench flats if pushrods have 40 threads per inch, and 30 wrench flats if your pushrods have 52 threads per inch. Tighten locknut.

**IMPORTANT NOTE:** This adjustment will make the pushrod tight, which will bleed the hydraulic lifter. It will take 10-15 minutes, or longer, to bleed off. It is very important that the engine is not rotated while pushrods are tight. The pushrod will spin with your fingers after it has bled off properly.

7. Recheck lock nut, close covers and install clips.
8. Repeat exact procedure on rear set.
9. Turn motor over several times to pump oil into the Power Glide™ Tappet or until the oil light goes out, or oil is returning to the oil tank.

USE JIMS® No.2369 PUSHRODS ON SHOVEL MOTORS OR H.D.® No.17904-66 OR EQUIVELANT  
USE JIMS® No.2404 PUSHRODS ON PANHEAD MOTORS OR H.D.® No.17905-53B OR EQUIVELANT

**CAUTION:** Use motorcycle oil 20-50w at best and clean the tappet filter screen.  
May also be used with 50w or 60w oil (See item E, below)

The following is sometimes mistaken for noisy tappets:

- A. The most common being the clearance between cam gears and pinion gear (referred to as gear lash). If you did not change the cams at the time of installing this kit and had no gear lash but a slight whine when motor was cold it is safe to say you are OK in this area.
- B. Rocker arm end play .004" to .010" is good.
- C. Oil pressure at normal operating temperature about 2000 r.p.m. should be 12-35 p.s.i..
- D. Check valve to guide clearance.
- E. If using 50w or 60w oil you may have a ticking noise at cold start, this is normal.

Pushrod Adjustments				
Threads per inch	Wrench Flats	Total Travel Distance	Distance Per Turn	Distance Per Flat
24	15	.1042"	.0417"	.0069"
28	17	.1011"	.0357"	.0059"
32	18	.0937"	.0313"	.0052"
36	21	.0965"	.0275"	.0045"
40	24	.100"	.025"	.0042"
52	30	.0962"	.0192"	.0032"

Popular Pushrods		
JIMS® Pro-lite	24	No.s 2380, 2400
Slim Jims	32	No.s 2404, 2369
Andrews	28	
Andrews	32	
Crane	28	New Time Savers
Crane	24	Old Time Savers
Crane	32	
H.D.	32	
S & S	32	
Screamin Egl.	32	
Rivera	40	Taper Lite
Rev Tech	36	

***"From the Track... To the Street!"***